



(877) 376-2839

Product Description Sheet

Permatex® #66 Clear Silicone Adhesive Sealant

PRODUCT DESCRIPTION

Permatex® Clear Silicone Adhesive Sealant is a general purpose, single component, room temperature vulcanizing gasketing compound, designed for the sealing of mechanical assemblies. Upon curing from the exposure to moisture in the air, this non-sagging paste forms a tough, flexible, waterproof seal of silicone rubber, which resists aging, weathering and thermal cycling without hardening, shrinking or cracking.

PRODUCT BENEFITS

- Easy application
- Applied to horizontal or vertical surfaces
- Superior adhesion and flexibility
- Waterproofs
- Insulates
- Unaffected by vibration
- Non-flammable
- Non-toxic

TYPICAL APPLICATIONS

Permatex® Clear Silicone Adhesive Sealant is an excellent all-purpose adhesive/sealant for the following materials:

- Metal
- Glass
- Wood
- Plastic
- Silicone resin
- Vulcanized silicone rubber
- Ceramics
- Natural and synthetic fibers
- Painted surfaces

Bonds, seals, repairs, mends and secures:

- Lens housings
- Windshields
- Windows
- Door frames
- Vinyl tops
- Housings and covers

DIRECTIONS FOR USE

For Assembly

1. Remove all previous material from mating surfaces. Permatex® Gasket Remover is recommended for most materials, not for plastics or painted surfaces.
2. For best results, clean and dry all surfaces with a residue-free solvent, such as Permatex® Brake and Parts Cleaner.
3. Cut nozzle to desired bead size, 1/16" to 1/4" in diameter. An 1/8" bead is usually sufficient for most applications.
4. Remove cap, puncture tube or cartridge seal and attach extension nozzle.

5. Apply a continuous and even bead of silicone to one surface, surrounding all bolt holes as shown below:

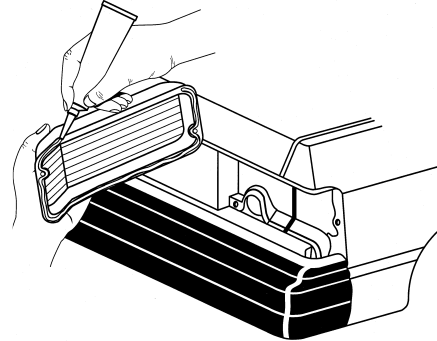

6. Assemble parts immediately while silicone is still wet. Secure or tighten as required, avoiding excessive squeeze-out.
7. Re-torque will not be necessary after the product has cured.

For Cleanup

1. Allow excess material to extend beyond the extension nozzle or aerosol tip to cure, sealing and protecting the remaining product from moisture. For reuse, simply remove the cured product from the tip.
2. Remove uncured product from parts and hand-tools with a dry cloth, if skinned over, break film with a dry cloth to remove as much as possible, and remove the remaining material with Permatex® Gasket Remover as previously stated.
3. Clean hands with a dry cloth or Permatex® Fast Orange hand cleaner.

PROPERTIES OF UNCURED MATERIAL

	Typical Value
Chemical Type	Acetoxy silicone rubber
Appearance	Clear non-sag paste
Odor	Mild acetic
Specific Gravity	1.01
Extrusion rate @ 25°C, (grams/min)	>220
Flash Point °C, °F	>93 (>200)

TYPICAL CURING PERFORMANCE

Permatex® Clear Silicone Adhesive Sealant cures on exposure to moisture in the air. The product cures tack free in 1 hour and fully cures in 24 hours. Cure times will vary with temperature, humidity and gap. Note: The curing process can cause corrosion to some surfaces, for critical applications use the Ultra Series silicones.

PERFORMANCE OF CURED MATERIAL

After 7 days at 25°C (77°F), 50% Relative Humidity

	Typical Values	
Hardness (Shore A)	>20	
*Elongation, %	>350	
**Tensile Strength, N/mm ² (psi)	>1.5	(>218)

*Material will stretch 3.5 times its original length before breaking.

**Amount of force required to break material.

TYPICAL ENVIRONMENTAL RESISTANCE

Temperature Resistance Typical Values

Continuous, °C (°F)	-59 to 204	(-75 to 400)
Intermittent, °C (°F)	-59 to 260	(-75 to 500)

Chemical / Solvent Resistance

The product retains effective properties in contact with automotive fluids, such as motor oil, transmission fluids, alcohol and antifreeze solutions. Note: Not recommended for parts in contact with gasoline.

GENERAL INFORMATION

This product is not recommended for use in pure oxygen and/or oxygen rich systems and should not be selected as a sealant for chlorine or other strong oxidizing materials.

For safe handling information on this product, consult the Material Safety Data Sheet, (MSDS).

Ordering Information

Part Number	Container Size
80636 (66B)	3 oz. tube, boxed
80050 (66BR)	3 oz. tube, carded
81856 (66LA)	4.5 oz. auto. tube
81913	8 oz. auto. tube
80855 (66C)	11 oz. cartridge

OEM Interchange

Manufacture	OEM Specifications Numbers	
BMW	07-58-9-062-376	11-21-1-262-571

Storage

Products shall be ideally stored in a cool, dry location in unopened containers at a temperature between 8° to 28°C (46° to 82°F) unless otherwise labeled. Optimal storage is at the lower half of this temperature range. To prevent contamination of unused product, do not return any material to its original container. For specific shelf-life information, contact your local Technical Service Center.

Note

The data contained herein are furnished for information only and are believed to be reliable. We cannot assume responsibility for the results obtained by others over whose methods we have no control. **Loctite Corporation specifically disclaims all warranties expressed or implied, including warranties of merchantability or fitness for a particular purpose, arising from sale or use of Loctite Corporation's products and disclaims any liability for consequential or incidental damages of any kind, including loss profits.** This product may be covered by one or more United States or foreign patents or patent applications.